

INDUSTRIAL CAMERA HOUSING
CHS50

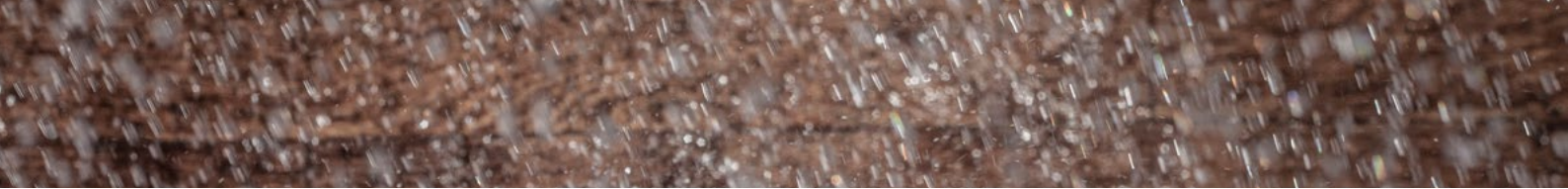

EN



CHS50 industrial camera housing

The CHS50 camera housing is designed for maximum durability and reliability in demanding industrial environments, including the food and chemical industries. Its stainless steel body provides not only mechanical protection but also passive cooling for the camera. The front part of the housing is adapted for easy lens adjustment, enhancing flexibility during installation. The housing is equipped with a cable gland for one or two cables, making the connection process easier. The easily removable front and rear parts ensure simple handling and maintenance. The IP68 protection rating with a resistance of up to 5 bars guarantees protection against dust and water, making the CHS50 an ideal choice for environments with high hygiene and durability requirements.

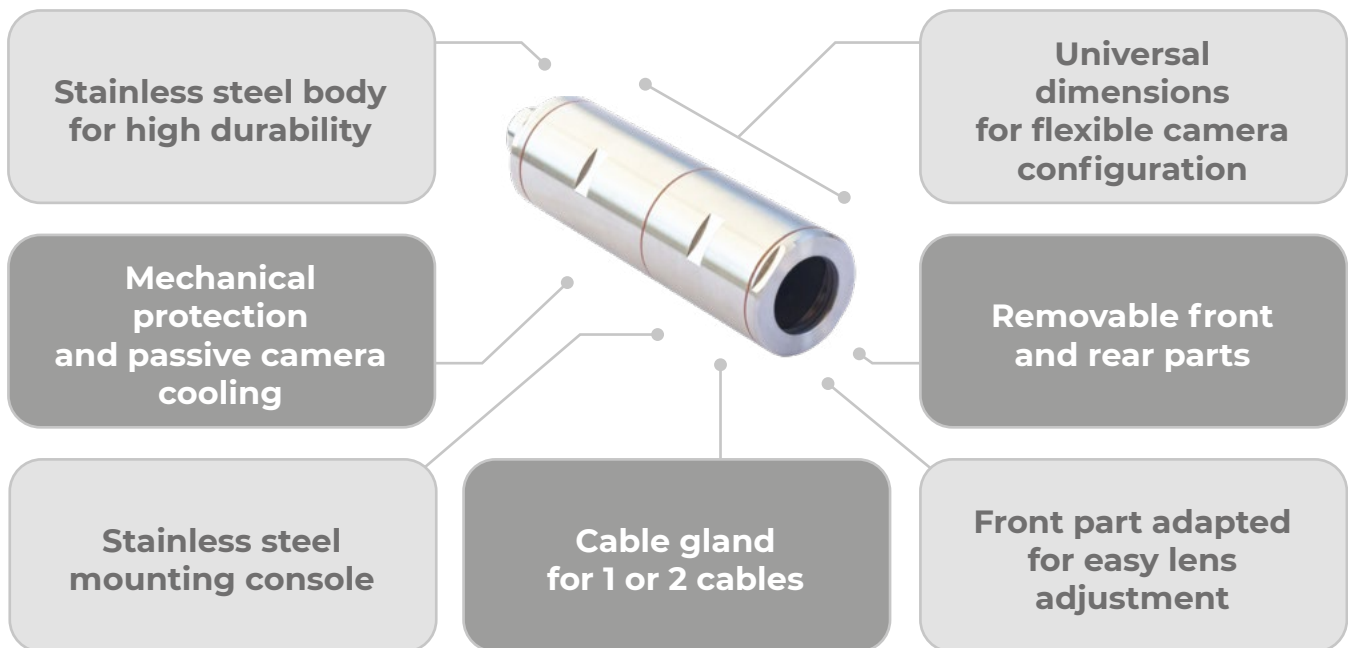

Material Properties

Body	Stainless steel 1.4541 (DIN X6CrNiTi 18-10, AISI 321) for the food industry, Stainless steel 1.4301 (DIN X5CrNi 18-10, AISI 304) for the chemical industry
Sealing	MVQ 85 – for profile (red), FDA Silicone – for profile (blue), MVQ 60 FDA – for glass
Window	N-BK7, anti-reflection coating MgF2 (standard 390~700 nm)
Cable gland	M25 nickel-plated brass, IP68 10bar, Atex Ex
Mounting kit	Stainless steel, console

Dimensions and Environment

External dimensions	Ø 60 x 220 mm
Internal dimensions	Ø 50 mm
Window	Ø 38 mm
Protection rating	IP68, 5 bar
Weight	1.5 kg

Product dimensions

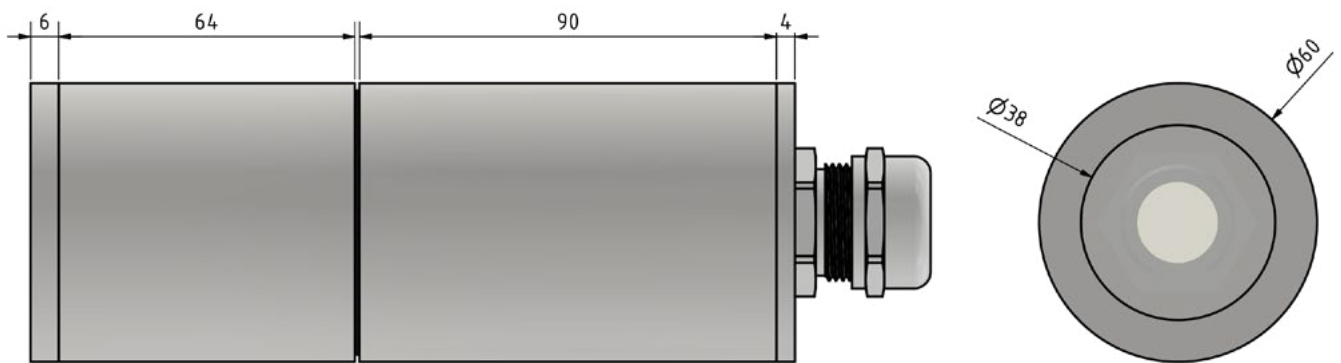

Standard housing dimensions (mm).

CHS50

Accessories

1. Cable gland with insert for 1 or 2 cables ϕ 4–6 mm.
2. Spacer for securing the camera.
3. 2x M2x6 screws and 2x M3x6 screws for fixing the camera to the fixed part of the spacer.
4. Stainless steel mounting console.

Product photo

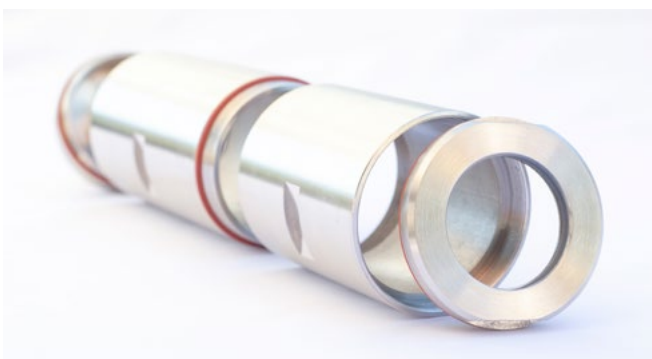

Argutec, s. r. o.

Na Nivách 1339/4
700 30 Ostrava-Zábřeh
Czech Republic

www.argutec.eu